



The Step-In Tub Experts!

CLEANCUT ULTRA-LOW INSTALLATION GUIDE

VIDEO INSTRUCTIONS
CAN BE VIEWED AT
WWW.CLEANCUTBATH.COM

COPYRIGHT © 2020 SAFEWAY SAFETY STEP, LLC
(DBA "CleanCut") All Rights Reserved

Reproduction or Distribution of this Installation Manual is Strictly Prohibited

****IMPORTANT – PLEASE WATCH INSTALLATION VIDEOS PRIOR TO READING DIRECTIONS AND BEFORE BEGINNING INSTALLATION****

VIDEO INSTRUCTIONS CAN BE VIEWED AT
WWW.CLEANCUTBATH.COM

IT IS VERY IMPORTANT THAT ALL INSTRUCTIONS IN THE INSTALLATION MANUAL ARE FOLLOWED THOROUGHLY.

INSTALLATION OF THE CLEAN CUT ULTRA-LOW REQUIRES USE OF POTENTIALLY DANGEROUS TOOLS.

SAFEWAY SAFETY STEP, LLC (DBA "CLEANCUT") ACCEPTS NO RESPONSIBILITY FOR ANY TYPE OF INJURY, LOSS OR DAMAGE OCCURRED DURING INSTALLATION OR SUBSEQUENT USE OF THE CLEAN CUT ULTRA-LOW.

FAILURE TO FOLLOW THE INSTRUCTIONS IN THIS INSTALLATION MANUAL SHALL VOID ANY WARRANTY GIVEN WITH RESPECT TO THE CLEAN CUT ULTRA-LOW.

IMPORTANT REMINDER - PLEASE REGISTER THE PRODUCT WARRANTY BY VISITING WWW.CLEANCUTBATH.COM/WARRANTY. ADDITIONAL CARE & USE AND WARRANTY INFORMATION IS INCLUDED IN THE KIT.

ADDITIONAL QUESTIONS?

CLEANCUT CUSTOMER SERVICE REPRESENTATIVES ARE AVAILABLE TO ANSWER QUESTIONS MONDAY-FRIDAY FROM 9AM-4PM EST. FOR QUESTIONS, PLEASE CALL 877-882-7837 OR VISIT WWW.CLEANCUTBATH.COM.

MSDS SHEET FOR ENCLOSED ADHESIVE AVAILABLE UPON REQUEST.

This manual includes an overview of the CleanCut Ultra-Low kit as well as step-by-step instructions for installation.

CleanCut Ultra-Low Installation Kit

The CleanCut Ultra-Low installation kit includes the following items:

- One CleanCut Ultra-Low
- One CleanCut Ultra-Low Support Box Structure (large & small box)
- Template to be used for cutting the tub
- Two tubes of required adhesive and angled extension nozzle

Tools & Materials

In addition to the items included in the installation kit, the following tools and materials are recommended to have on hand for installation.

Additional Tools & Materials

Butane Torch	Mirror (small)
Cardstock Paper	Paper Towels
Caulking Gun	Jigsaw with 2" Blade
Chisels	Masking Tape
Deburring Tool (i.e. drywall plane, rasp)	Pliers
Drain Screens	Pressure Treated 2x4's
Drill & Drill Bits	Protective Eye Wear
Drop Cloths	Reciprocating Saw with Metal Blade
Dust Masks	Scissors
Dustpan & Brush	Screwdriver
Ear Protection	Screws- Assorted Sizes
Extension Cord	Sharpie Marker (colored)
Fire Extinguisher	Side Grinder with 4.5" Diamond Blade
Gloves	Utility Knife
Hammer	Vacuum with Attachment
Isopropyl Alcohol	Wood Shims

VIDEO INSTRUCTIONS CAN BE VIEWED AT WWW.CLEANCUTBATH.COM

Preparing the Tub

1. Before beginning any work, it is important to inspect the tub for existing chips, markings or other types of damage. It is always wise to make the owner or manager aware of any existing damage prior to beginning the installation process.
2. Prior to beginning the installation, remove any personal items from the bathroom area to create extra space during the installation and to prevent possible damage or exposure to dust and debris that may result during the installation process.
3. One method to minimize the areas where dust can settle is to use a 2-ply drop cloth with the paper side up to catch and trap dust and other shavings. In particular, a drop cloth should be taped into the bottom of the tub. This will help to collect debris as well as to help prevent accidentally scratching the bottom surface of the tub. The drain of the tub should be completely covered to prevent any shaving from going down into the drain. Make sure that there is no water or dampness in or around the tub.

Due to the significant amount of dust created when cutting a cast-iron tub, it is recommended that all walls and surfaces are covered, including the floor, before cutting the tub. See other considerations for cutting cast-iron tubs in the following section.

4. Confirm that the CleanCut Ultra-Low will fit the bathtub. First, measure the top rail width measurement as well as the width measurement approximately 14.75" down the tub (bottom measurement)
 - The maximum top rail measurement to install the CleanCut Ultra- Low is 6".
 - The maximum bottom measurement to install the CleanCut Ultra- Low is 7.25".
5. Mark the tub to determine the section that will be cut to make room for the CleanCut Ultra-Low. If installing the Ultra-Low in the middle of the bathtub, measure the length of the tub and determine the midpoint of the tub. Measure and mark 14" on either side of the center mark. Using the template that was included in the installation kit, place the template flush against the tub and begin tracing, use a colored sharpie marker so as to make the lines that are traced easily visible. Flip the template over and now trace the outside of the tub. Keep in mind that it may not be possible to place the CleanCut Ultra-Low directly in the center of the tub due to obstructions in the tub area such as the placement of sinks, vanities or commodes and the use of shower seats may warrant moving the opening forward as well.

Cutting the Tub

The tub has been marked and is ready to cut.

Safety Considerations

- Safety is of highest importance and it is critical to remember to use the proper safety equipment when cutting the tub.
- Protective eye and ear wear and filter mask are required.
- Be cognizant of potential safety issues when cutting the tub such as sparks generated during cutting as well as items that may be located within the tub wall such as water lines, electrical lines, insulation, etc.

The CleanCut Ultra-Low can be installed in acrylic, fiberglass, steel or cast-iron tubs. On acrylic, fiberglass or steel tubs, use a side grinder with the diamond blade to make necessary entry points for the reciprocating saw. For cast-iron tubs, the side grinder with the diamond blade is the only cutting tool used. If you are cutting a cast-iron tub, please read the special considerations noted below before beginning to cut.

1. The first corner notches will be made with the side grinder as illustrated in Figure 1 below.
2. Using the reciprocating saw on acrylic, fiberglass and steel tubs, cut out the bottom markings on each side of the tub.
3. Then cut all four downward cuts. Finish by cutting the two adjoining top pieces.
4. The opening for the CleanCut Ultra-Low is now completed and you can remove the cut-out section. Use caution when removing the cut-out section as there may be sharp or jagged edges both on the cut-out segment and along the edges of where the cuts were made on the sides of the tub. It is helpful to spend a moment to file down any potential hazard areas. This prevents potential snags with fitting the CleanCut Ultra-Low and reduces risk of injury.

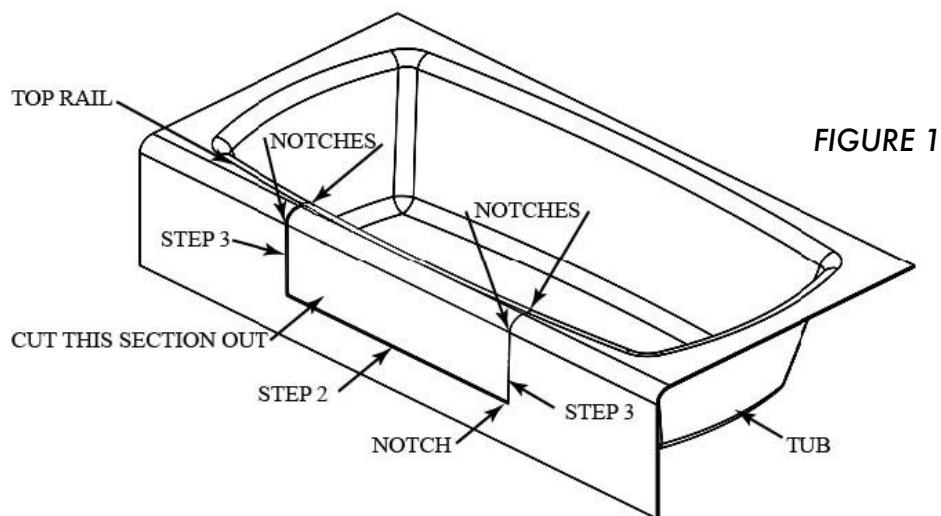

FIGURE 1

5. After the cut-out section of the tub has been removed, take a few moments to clean the area in and around the tub. Using a dustpan and broom, sweep all dust and shavings. Complete the clean-up by thoroughly vacuuming the entire area. Wash your hands before you start any work on the Ultra-Low itself. This will eliminate transferring any dirt or dust to the product.

SPECIAL CONSIDERATIONS FOR CUTTING CAST-IRON TUBS

CleanCut recommends professional installation when installing on cast-iron tubs.

Due to the significant amount of dust created when cutting a cast-iron tub, it is recommended that you cover all tub and exposed bathroom walls and surfaces (including the floor) with a 2-ply drop cloth to minimize the amount of dust that can settle. Also, it is recommended that the installer wears protective coveralls and shoe covers, in addition to protective wear outlined earlier, to minimize the clean-up after cutting out a cast-iron tub.

Please note that there are several differences when cutting out a cast-iron tub compared to other types of tubs. The side-grinder with a 4.5" diamond blade is the only tool used when cutting a cast-iron tub. Cast-iron tubs are a bit more challenging to cut. Vacuum the dust and shavings as you cut the tub.

Follow the same pattern when cutting a cast-iron tub as described for the other tub types. Begin by cutting the bottom lines of your template, followed by the downward vertical cuts, leaving the top adjoining pieces for last.

Measuring & Cutting the CleanCut Ultra-Low

Once you have completed cutting out the section of the tub, you can begin to fit the CleanCut Ultra-Low into the tub opening. Please note that the Ultra-Low should be installed with the logo showing on the outside of the tub.

1. Take a stack of heavy cardstock paper. This is the paper used to trace the cut-out section of the tub onto the CleanCut Ultra-Low. Place the paper onto the left end and trace the outline of the pattern onto the paper. Once completed, mark this tracing as "Left", so as to remember which side was traced. It is also helpful to place an arrow on the template to indicate which direction is the inside of the tub.
2. Repeat the process for the right side of the tub. Mark this tracing "Right".
3. Cut out the paper templates with scissors making sure to keep to the inside of the tracings (Figure 2).

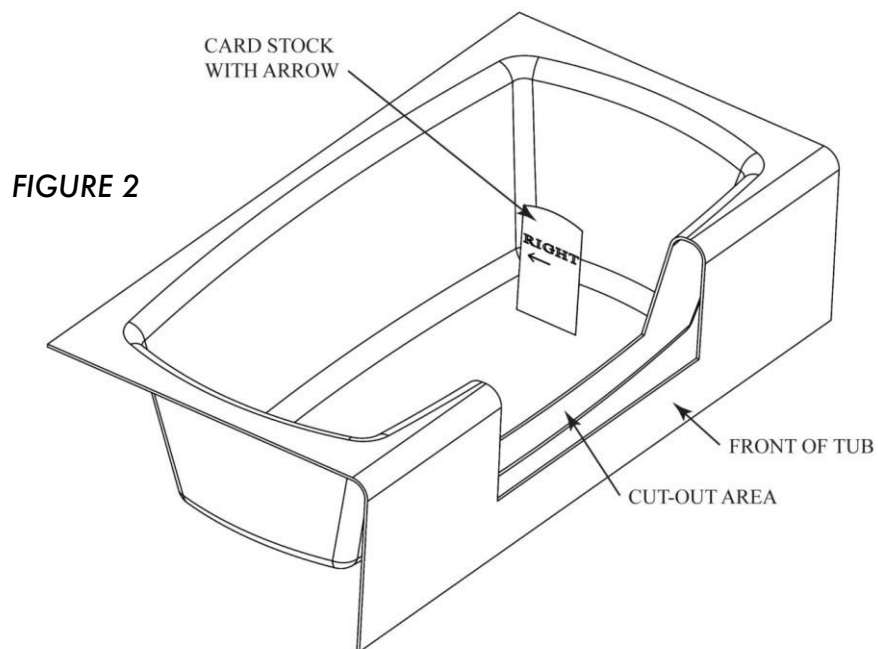

4. It is time to transfer the shape of our cut tub onto the CleanCut Ultra-Low. Before continuing, it is recommended that a drop cloth approximately 3' x 4' size be placed on the floor to prevent any dust or other debris from transferring onto the CleanCut Ultra-Low.
5. Place the right end of the CleanCut Ultra-Low on the ground in order to trace the left side of the CleanCut Ultra-Low. Place the top of the paper template approximately 1" from the top of the CleanCut Ultra-Low (Figure 3). Place the tracing on the CleanCut Ultra-Low so that the slope is similar to that of the tub. Trace the outline of the paper onto the CleanCut Ultra-Low with a continuous line. Continue the lines with a straight edge down and around the corners. Repeat the same procedure for the right end of the CleanCut Ultra-Low. Remember to place the paper template approximately 1" down from the top of the CleanCut Ultra-Low before beginning to trace. Continue the lines with a straight edge down and around the corners.

FIGURE 3
SIDE VIEW OF
LEFT END OF
ULTRA-LOW

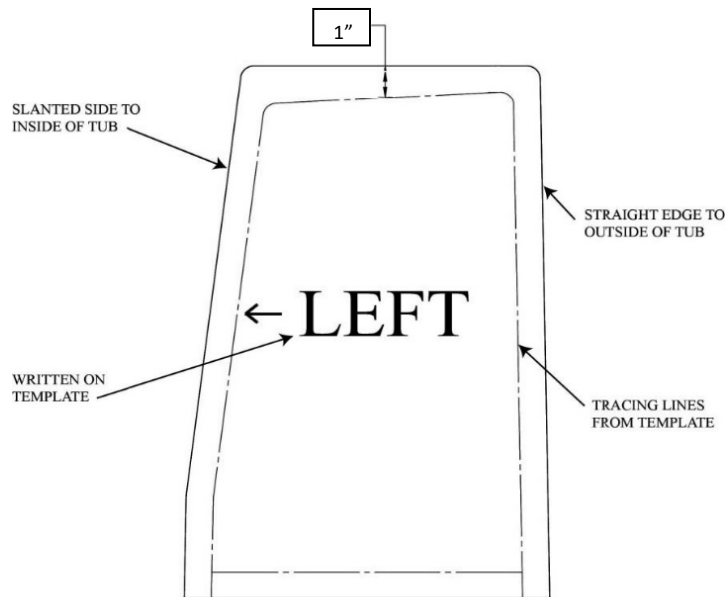

- Place the Ultra-Low as shown in Figure 4. Use a tape measure and transfer the shape of the inside of the tub edge to the Ultra-Low. The inside of the tub may be irregular in shape, so measurements for the inside line must be made every 3" from one end of the CleanCut Ultra-Low to the other. Once completed, use your yard stick and marker to connect the markings for the inside line.

Alternate Method: You may use cardstock paper such as done with the sides to create a bottom template.

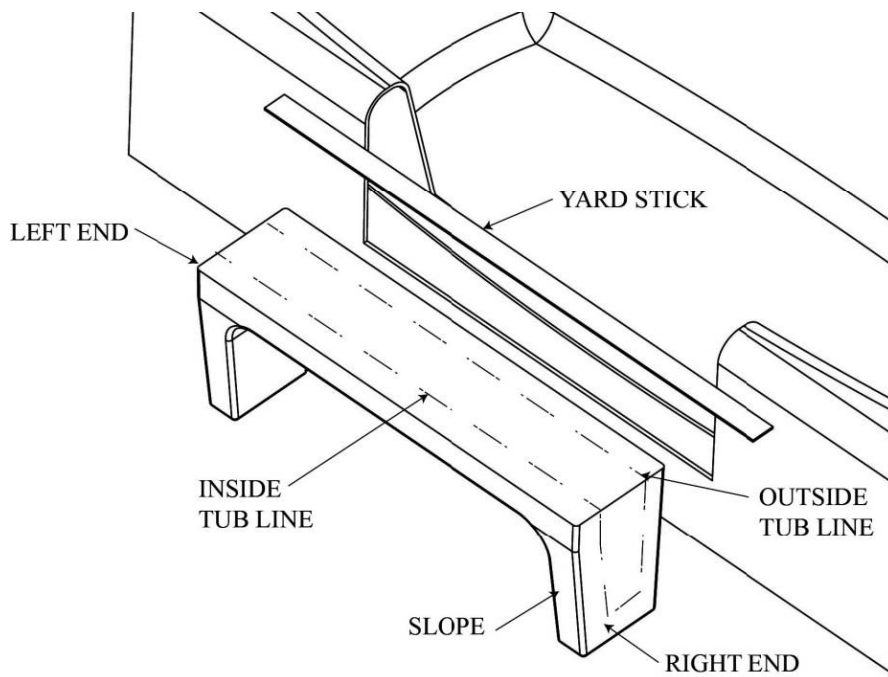

FIGURE 4

7. Cut the CleanCut Ultra-Low to fit the cut-out tub opening using a jigsaw (Figure 5). Fasten Velcro-stripping on both sides of the jigsaw to prevent making any unwanted marks on the CleanCut Ultra-Low. It is important that a blade less than 2" is used to cut out the CleanCut Ultra-Low so as to prevent accidentally cutting through the top of the Ultra-Low. Snap off any excess length on the stock jigsaw blade beyond 2".

USE THE JIGSAW TO CUT THE LINES TRACED ON THE ULTRA-LOW.

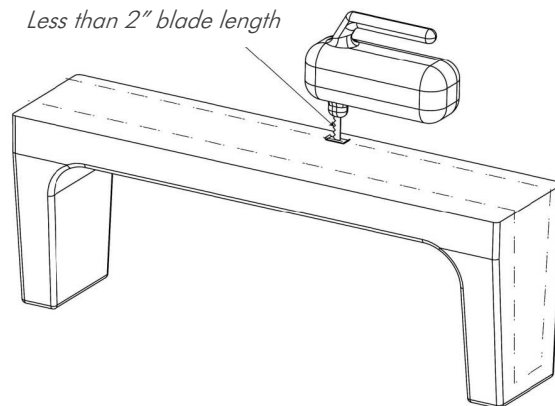

FIGURE 5

It is required that proper eye protection be worn while using the jigsaw. Cut directly on the center of the traced lines. Upon reaching the corners while cutting, tilt the jigsaw outward to prevent cutting past your lines on the vertical ends of the CleanCut Ultra-Low. Remember to tilt your blade on each corner, cutting all areas that have been marked.

8. Place the CleanCut Ultra-Low into position. Remember, the face with the CleanCut logo is on the outside of the tub. Use a small pocket mirror and look for areas on the CleanCut Ultra-Low that may be catching and prohibiting the CleanCut Ultra-Low from freefalling onto the tub. Use the jigsaw or drywall plane to trim the CleanCut Ultra-Low where necessary.
9. Continue this process and repeat as necessary until a desirable close fit is achieved. The CleanCut Ultra-Low should free fall onto the tub without catching or binding. Once final adjustments have been made, use a drywall plane or deburring tool (a common potato peeler works well) to trim the remaining edges.
10. Having completed use of the jigsaw, take a moment to tidy the tub and work area.

Support Box Structure Installation

Once the CleanCut Ultra-Low has been cut and a satisfactory fit into the tub opening is achieved, it will be necessary to assemble the support box structure to provide support to the CleanCut Ultra-Low. An example of the CleanCut Ultra-Low and the support box structure is illustrated in Figure 6.

The CleanCut Support box structure consists of one small and one large support box. The large support box will compress over the top of the small box to the necessary height to provide support to the CleanCut Ultra-Low.

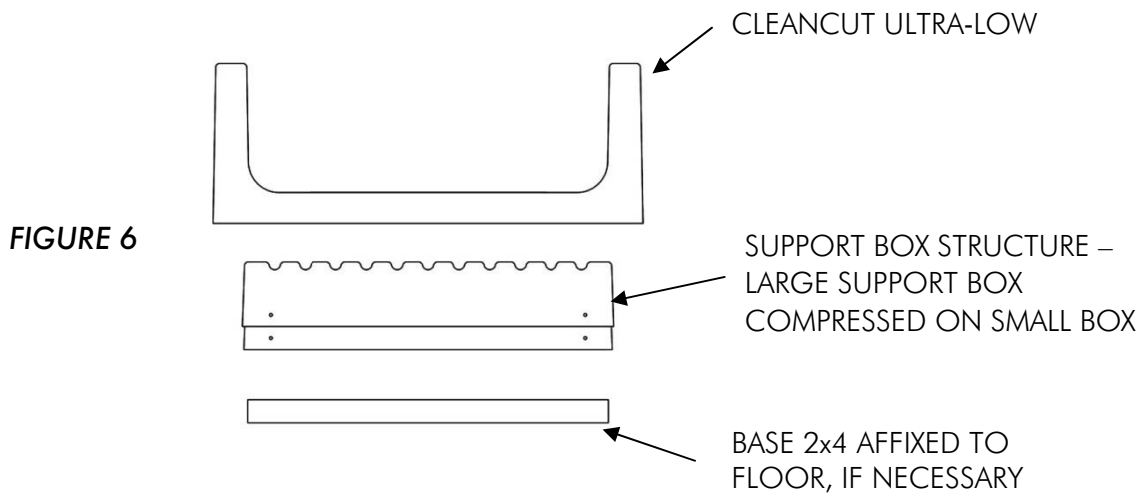

It is important to understand that each tub has variations and modifications may be necessary in the field. For fiberglass and other types of tubs, it may be necessary to adjust the installation of the support boxes based on the framing or support material present on the inside channel of the tub. For example, you may only need to use one of the support box structures based on the height of the bathtub.

1. It may be necessary to adjust the support box structure according to the conditions present during your installation. For example, for wooden sub-floors, begin by screwing or adhering with included adhesive a treated 2x4 directly to the sub-floor to serve as a base for the support structure. For concrete floors, a treated 2x4 is adhered directly to the concrete floor with adhesive. The 2x4 might need to be cut into several sections if there is a support brace in the cut-out channel.
2. Build the support box structure to appropriate height. If working with a concrete sub-floor, thoroughly inspect and clean the floor in the tub cut-out channel prior to securing the treated 2x4. Remove any materials from the concrete that may cause an uneven surface. Apply adhesive directly to the concrete floor. Insert the 2x4s and thoroughly spread the adhesive on the concrete.
3. Prior to inserting the small support box, it is first necessary to secure a 22 ½" long 2x4 into the channel of the small support box. Place a bead of adhesive around the inside of the support box and insert the 2x4. Place several screws into the small support box to properly affix the 2x4 into proper position (Figure 7).

Small Support Box

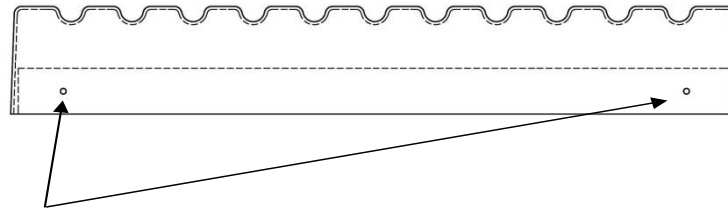

Drywall Screws Holding 2x4s (each side)

FIGURE 7

4. Insert the small box in the channel. At this point, do not adhere the small support box to anything. Place the large support box into the channel and over the top of the small box. Place the CleanCut Ultra-Low into position and compress the CleanCut Ultra-Low downward to determine the proper height and placement for the support box structure.
5. Once the support of the CleanCut Ultra-Low has been achieved, remove the Ultra-Low and mark both the left and right ends of the small box where the large box is compressed while the boxes are in the tub opening channel. Once properly marked, remove both support boxes and label the markings "Left" and "Right" to avoid potential confusion. Uncompress the two support boxes from one another and begin the process to permanently adhere the boxes in proper position.
6. Apply adhesive around the perimeter of the large box. Compress the small and large support box structures back together to the appropriate markings made earlier on the small box. Place the support structure back into the channel and insert the CleanCut Ultra-Low to verify that proper placement has been achieved. Secure both sides of the support structure by placing two screws in each side (Figure 8).

1 1/4" Drywall Screws

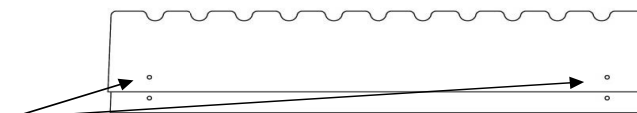

FIGURE 8

7. Apply adhesive to the tops of the 2x4's that are already in place in the channel, if they are needed for height adjustment and insert the support box structure.
8. Place the CleanCut Ultra-Low into the channel once more to inspect the fit and position. This is the final opportunity to make any adjustments if necessary.
9. Apply adhesive to the top of the large support box. It is recommended that an extra bead of adhesive be placed on the ends of the large support box as the CleanCut Ultra-Low curves up toward the ends. Place a substantial bead of adhesive on the top left and right side of the tub where the CleanCut Ultra-Low will be seated. Adhesive on the top of the tub reinforces the CleanCut Ultra-Low.
10. Prior to placing the CleanCut Ultra-Low into the channel, it is necessary to gently pass a low flame several times along the perimeter of the Ultra-Low where the tub is met. This will help promote bonding between the CleanCut Ultra-Low and the bathtub where adhesive is applied. Use caution when using the torch and do not hold heat on one area of the product as it may discolor or melt.
11. Place the CleanCut Ultra-Low into the channel and gently press into place.

Completing the Installation

1. Before finalizing installation, make sure the CleanCut Ultra-Low is in proper position and fully compressed. Press firmly and evenly on the CleanCut Ultra-Low to ensure proper placement. Thoroughly wipe tub area with isopropyl alcohol where the adhesive will bond and allow enough time for the isopropyl alcohol to flash off before applying the adhesive. **Do not** apply the isopropyl alcohol directly on the adhesive as it will prevent the adhesive from drying or curing. **Do not** use to clean or smooth your final bead.
2. It is necessary to caulk around the entire perimeter of the CleanCut Ultra-Low using the enclosed adhesive. Begin by using adhesive along the inside of the CleanCut Ultra-Low, one section at a time. Begin on the left inside and complete the application process, before moving to the bottom inside, then the right inside. Complete the same steps on the outside. It is recommended that you wear gloves during this step to avoid direct exposure to the adhesive.
3. Run your gloved finger along the beads and wipe the excess on a folded paper towel. Try to smooth the beads one-time only, as the adhesive becomes tacky to the touch quickly.
4. Underneath the bottom edges of the CleanCut Ultra-Low are a bit more difficult to see and the included angled nozzle should be used in completing this step. Use a small mirror to inspect the bead and to verify that all surfaces have been properly sealed.
5. It is also recommended to remove the stopper from the tub upon completion of the installation to prevent from accidentally filling the tub with water and, if desired, replace trip lever with a blank cap.
6. Spend some time at the end of the job to again clean up the tub and bathroom area. Upon completion, place a sign on CleanCut Ultra-Low warning not to use the tub for 2 days while the adhesive cures.

IMPORTANT REMINDER – if completing the install on behalf of another, please leave the warranty and care & use information with the end-user at the conclusion of the installation.

The CleanCut Ultra-Low installation is now complete. Safeway Safety Step, LLC (DBA CleanCut) sincerely thanks you for your interest in the CleanCut Ultra-Low and looks forward to assisting you in any way possible. Visit our website at www.cleancutbath.com for video installation instructions and answers to frequently asked questions, or call us toll-free at 877-882-7837 with any questions or concerns.