



The Step-In Tub Experts!

CLEANCUT DOOR INSTALLATION GUIDE

VIDEO INSTRUCTIONS
CAN BE VIEWED AT
WWW.CLEANCUTBATH.COM

COPYRIGHT © 2020 SAFEWAY SAFETY STEP, LLC
(DBA "CleanCut") All Rights Reserved

Reproduction or Distribution of this Installation Manual is Strictly Prohibited

****IMPORTANT - PLEASE WATCH INSTALLATION VIDEOS PRIOR TO READING DIRECTIONS AND BEFORE BEGINNING INSTALLATION****

VIDEO INSTRUCTIONS CAN BE VIEWED AT
WWW.CLEANCUTBATH.COM

IT IS VERY IMPORTANT THAT ALL INSTRUCTIONS IN THE INSTALLATION MANUAL ARE FOLLOWED THOROUGHLY.

INSTALLATION OF THE CLEAN CUT DOOR REQUIRES USE OF POTENTIALLY DANGEROUS TOOLS.

SAFEWAY SAFETY STEP, LLC (DBA "CLEAN CUT") ACCEPTS NO RESPONSIBILITY FOR ANY TYPE OF INJURY, LOSS OR DAMAGE OCCURRED DURING INSTALLATION OR SUBSEQUENT USE OF THE CLEAN CUT DOOR.

FAILURE TO FOLLOW THE INSTRUCTIONS IN THIS INSTALLATION MANUAL SHALL VOID ANY WARRANTY GIVEN WITH RESPECT TO THE CLEAN CUT DOOR.

IMPORTANT REMINDER - PLEASE REGISTER THE PRODUCT WARRANTY BY VISITING WWW.CLEANCUTBATH.COM/WARRANTY. ADDITIONAL CARE & USE AND WARRANTY INFORMATION IS INCLUDED IN THE KIT.

ADDITIONAL QUESTIONS?

CLEAN CUT CUSTOMER SERVICE REPRESENTATIVES ARE AVAILABLE TO ANSWER QUESTIONS MONDAY-FRIDAY FROM 9AM-4PM EST. FOR QUESTIONS, PLEASE CALL 877-882-7837 OR VISIT WWW.CLEANCUTBATH.COM.

MSDS SHEET FOR ENCLOSED ADHESIVE AVAILABLE UPON REQUEST.

This manual includes an overview of the CleanCut Door kit as well as step-by-step instructions for installation.

CleanCut Door Installation Kit

The CleanCut Door installation kit includes the following items:

- One CleanCut Door (large/wide, medium or small/narrow)
- One CleanCut Door Support Box Structure (large & small box)
- Template to be used for cutting the tub
- Two tubes of required adhesive and angled nozzle
- Waterproof membrane wrap
- Furring/Spacing strip

Tools & Materials

In addition to the items included in the installation kit, the following tools and materials are recommended to have on hand for installation.

Additional Tools & Materials

Butane Torch	Jigsaw with 2" Blade
Cardstock Paper	Masking Tape
Caulking Gun	Mirror (small)
Chisels	Paper Towels
Deburring Tool (i.e. drywall plane, rasp)	Pliers
Drain Screens	Pressure Treated 2x4's
Drill & Drill Bits	Protective Eye Wear
Drop Cloths	Reciprocating Saw with Metal Blade
Dust Masks	Scissors
Dustpan & Brush	Screwdriver
Ear Protection	Screws- Assorted Sizes
Extension Cord	Sharpie Marker (colored)
Fire Extinguisher	Side Grinder with 4.5" Diamond Blade
Gloves	Utility Knife
Hammer	Vacuum with Attachment
Isopropyl Alcohol	Wood Shims

VIDEO INSTRUCTIONS CAN BE VIEWED AT WWW.CLEANCUTBATH.COM

Preparing the Tub

1. Before beginning any work, it is important to inspect the tub for existing chips, markings or other types of damage. If doing work on behalf of others, make the resident or property manager aware of any existing damage prior to beginning the installation process. Existing damage may be made worse during the tub cutting process.
2. Prior to beginning the installation, remove any personal items from the bathroom area to create extra space during the installation and to prevent possible damage or exposure to dust and debris that may result during the installation process.
3. One method to minimize the areas where dust can settle is to use a 2-ply drop cloth with the paper side up to catch and trap dust and other shavings. In particular, a drop cloth should be taped into the bottom of the tub. This will help to collect debris as well as to help prevent accidentally scratching the bottom surface of the tub. The drain of the tub should be completely covered to prevent any shaving from going down into the drain. Make sure that there is no water or dampness in or around the tub.

Due to the significant amount of dust created when cutting a cast-iron tub, it is recommended that all walls and surfaces are covered, including the floor, before cutting the tub. See other considerations for cutting cast-iron tubs in the following section.

4. Confirm that the CleanCut Door will fit the bathtub. The CleanCut Door is manufactured in three (3) sizes to fit tubs of varying widths. First, measure the top rail width measurement as well as the width measurement approximately 10.5" down the tub (bottom measurement). Based on these measurements, please consider the following:
 - Small/Narrow: maximum top and bottom rail measurements 5.25".
 - Medium: maximum top and bottom rail measurements 6.5".
 - Large/Wide: maximum top and bottom rail measurements 7.5".
5. Mark the tub to determine the section that will be cut to make room for the CleanCut Door. If installing the CleanCut Door in the middle of the bathtub, measure the length of the tub and determine the midpoint of the tub. Measure and mark 11.75" on either side of the center mark. Using the template that was included in the installation kit, place the template flush against the tub and begin tracing. Use a colored sharpie marker so as to make the lines that are traced easily visible. Flip the template over and now trace the outside of the tub. Keep in mind that it may not be possible to place the CleanCut Door directly in the center of the tub due to obstructions in the tub area such as the placement of sinks, vanities or commodes. It may be advisable to offset the CleanCut Door to accommodate other safety features, such as grab bars or bath seats.

Cutting the Tub

The tub has been marked and is ready to cut.

Safety Considerations

- Safety is of highest importance and it is critical to remember to use the proper safety equipment when cutting the tub.
- Protective eye and ear wear and filter mask are required.
- Be cognizant of potential safety issues when cutting the tub such as sparks generated during cutting as well as items that may be located within the tub wall such as water lines, electrical lines, insulation, etc.

The CleanCut Door can be installed in acrylic, fiberglass, steel or cast-iron tubs. On fiberglass or steel tubs, use a side grinder with the diamond blade to make necessary entry points for the reciprocating saw. For cast-iron tubs, the side grinder with the diamond blade is the only cutting tool used. If you are cutting a cast-iron tub, please read the special considerations noted below before beginning to cut.

1. The first corner notches will be made with the side grinder as illustrated in Figure 1 below.
2. Using the reciprocating saw on fiberglass and steel tubs, cut out the bottom markings on each side of the tub.

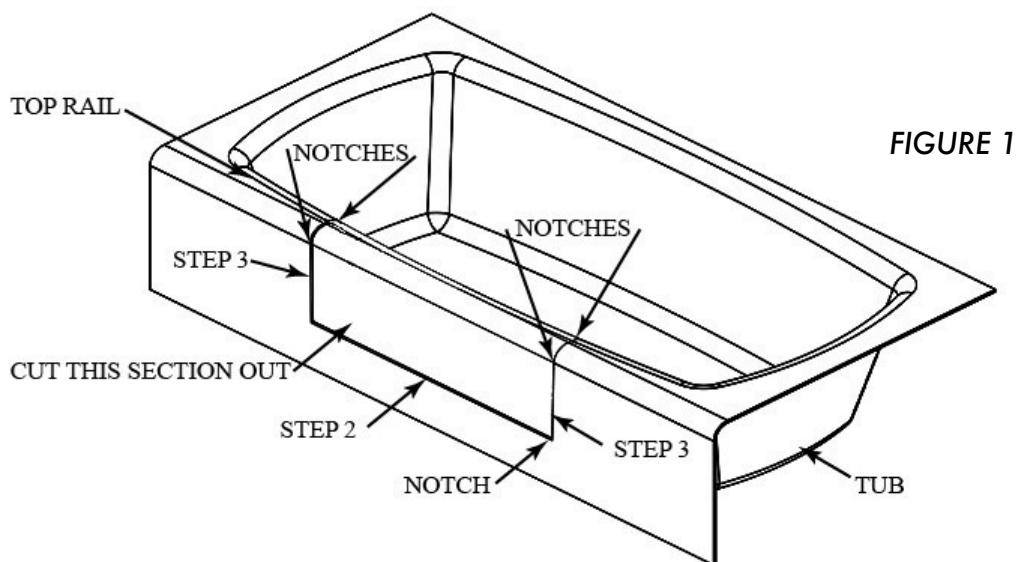

3. Then cut all four downward cuts. Finish by cutting the two adjoining top pieces.
4. The opening for the CleanCut Door is now complete and you can remove the cut-out section. Use caution when removing the cut-out section as there may be sharp or jagged edges both on the cut-out segment and along the edges of where the cuts were made on the sides of the tub. It is helpful to spend a moment to file down any potential hazard areas. This prevents potential snags with fitting the CleanCut Door and reduces the risk of injury.
5. After the cut-out section of the tub has been removed, take a few moments to clean the area in and around the tub. Using a dustpan and broom, sweep all dust and shavings. Complete the clean-up by thoroughly vacuuming the entire area. Wash your hands before you start any work on the Door itself. This will eliminate transferring any dirt or dust to the product.

SPECIAL CONSIDERATIONS FOR CUTTING CAST-IRON TUBS

CleanCut recommends professional installation when installing on cast-iron tubs.

Due to the significant amount of dust created when cutting a cast-iron tub, it is recommended that you cover all tub and exposed bathroom walls and surfaces (including the floor) with a 2-ply drop cloth to minimize the amount of dust that can settle. Also, it is recommended that the installer wears protective coveralls and shoe covers, in addition to protective wear outlined earlier, to minimize the clean-up after cutting out a cast-iron tub.

Please note that there are several differences when cutting out a cast-iron tub compared to other types of tubs. The side-grinder with a 4.5" diamond blade is the only tool used when cutting a cast-iron tub. Cast-iron tubs are a bit more challenging to cut. Vacuum the dust and shavings as you cut the tub. Follow the same pattern when cutting a cast-iron tub as described for the other tub types. Begin by cutting the bottom lines of your template, followed by the downward vertical cuts, leaving the top adjoining pieces for last.

Measuring & Cutting the CleanCut Door

Once you have completed cutting out the section of the tub, you can begin to fit the CleanCut Door into the tub opening. Please note that the Door should be installed with the embossed "Safeway Safety Step" lettering showing on the outside of the tub, and the metal hinges towards the inside of the tub.

1. Take a stack of heavy cardstock paper. This is the paper used to trace the cut-out section of the tub onto the CleanCut Door. Place the paper onto the left end and trace the outline of the pattern onto the paper. Once completed, mark this tracing as "Left", so as to remember which side was traced. It is also helpful to place an arrow on the template to indicate which direction is the inside of the tub.
2. Repeat the process for the right side of the tub. Mark this tracing "Right".
3. Cut out the paper templates with scissors making sure to keep to the inside of the tracings (Figure 2).

FIGURE 2

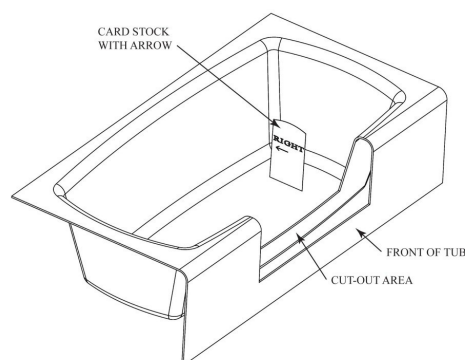

4. It is time to transfer the shape of our cut tub onto the CleanCut Door. Before continuing, it is recommended that a drop cloth approximately 3' x 4' size be placed on the floor to prevent any dust or other debris from transferring onto the CleanCut Door.
5. Place the left end of the CleanCut Door on the ground in order to trace the right side of the CleanCut Door. Place the top of the paper template approximately 1/2" from the top of the CleanCut Door. Place the tracing on the Door so the slope is similar to that of the tub. Trace the outline of the paper onto the CleanCut Door. Continue the lines with a straight edge down and around the corners. Repeat the same procedure for the left end of the CleanCut Door. Remember to place the paper template approximately 1/2" down from the top of the CleanCut Door. Continue the lines with a straight edge down and around the corners (Figure 3).

FIGURE 3

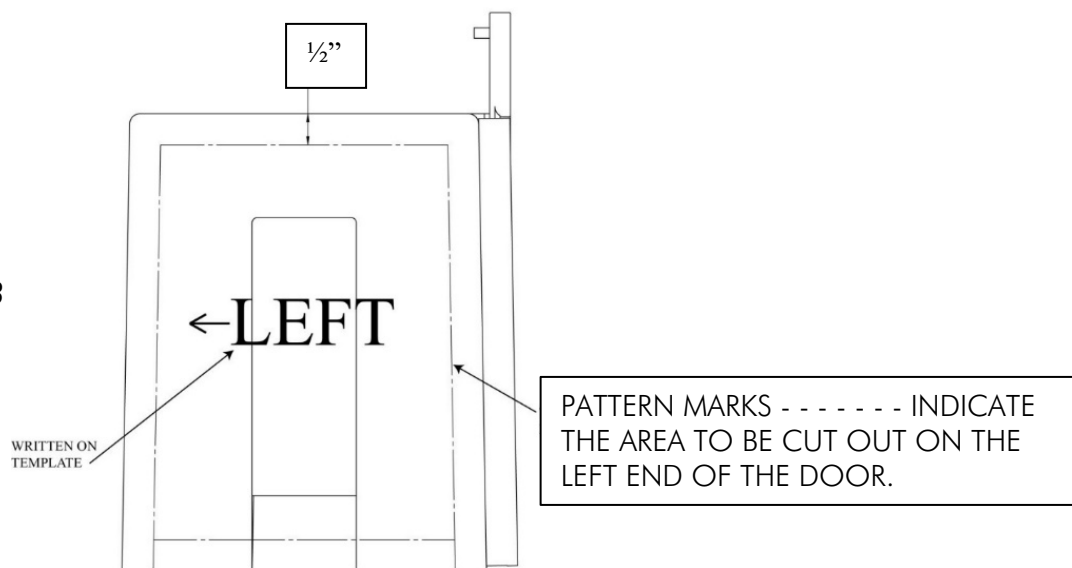

6. Next, place door as shown and connect each side of the outside tub line using a yard stick. Note that when inverting the CleanCut Door, it is necessary to reposition the handle so that the handle does not rest directly onto the ground.
7. Place the CleanCut Door as shown in Figure 4. Note that when inverting the Door, it is necessary to reposition the handle so that the handle does not rest directly onto the ground. Use a tape measure and transfer the shape of the inside of the tub edge to the step. Remember that the tub may be narrower in the center, so measurements for the inside line must be made every 3" from one end of the Door to the other. Once completed, use your yard stick and marker to connect the markings for the inside line.

Alternate Method: You may use cardstock paper such as done with the sides to create a bottom template.

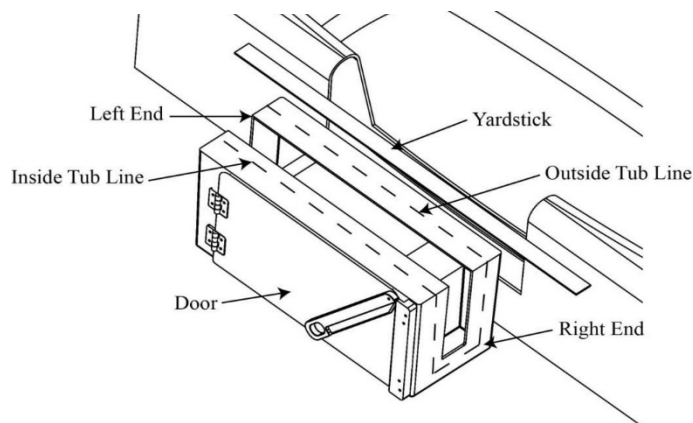
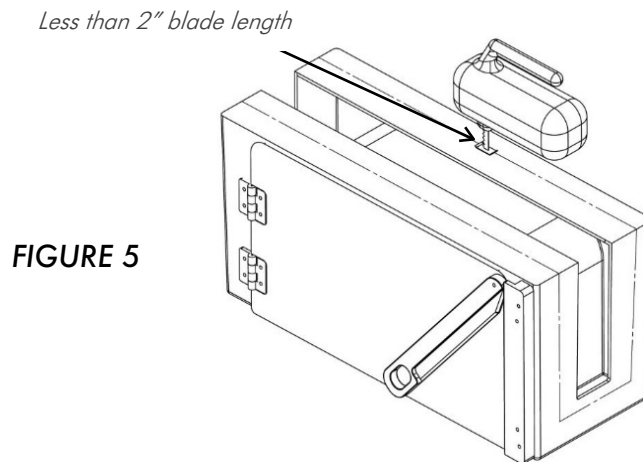

FIGURE 4

8. Cut the CleanCut Door to fit the cut-out tub opening using a jigsaw and routing tool. (Figure 5). Fasten Velcro-stripping on both sides of the jigsaw to prevent making any unwanted marks on the CleanCut Door. It is important that a blade less than 2" is used to cut out the CleanCut Door so as to prevent accidentally cutting through the top of the Door. Snap off any excess length on the stock jigsaw blade beyond 2".



It is required that proper eye protection be worn while using the jigsaw. Cut the bottom of the CleanCut Door using the jigsaw on the side opposite the door cutting directly on the center of the traced lines. Upon reaching the corners while cutting, tilt the jigsaw outward to prevent cutting past your lines on the vertical ends of the CleanCut Door. Remember to tilt your blade on each corner. On the ends of the Door, simply continue the cutting process with the jigsaw.

9. Use the routing tool to cut the horizontal side closest to the door to prevent accidentally cutting into the door channel.
10. Use a drywall plane or deburring tool to rid the CleanCut Door of any remaining pieces.
11. Place the CleanCut Door into position. Remember, the side with the door is placed on the inside of the tub. Use a small pocket mirror and look for areas on the CleanCut Door that may be catching and prohibiting the CleanCut Door from freefalling onto the tub. Use the jigsaw or drywall plane to trim the CleanCut Door where necessary.
12. Continue this process and repeat as necessary until a desirable close fit is achieved. The CleanCut Door should free fall onto the tub without catching or binding.
13. Having completed use of the jigsaw and routing tool, take a moment to tidy the tub and work area.

Support Box Structure & Waterproof Membrane Installation

Once the CleanCut Door has been cut and a satisfactory fit into the tub opening has been achieved, it will be necessary to assemble the support box structure to provide support to the CleanCut Door. Once the support box has been properly positioned, a waterproof membrane will be applied to the open cut-out channel. An example of the CleanCut Door and the support box structure and waterproof membrane is illustrated in Figure 6.

The CleanCut support box structure consists of one small and one large support box. The large support box will compress over the top of the small box to the necessary height to provide support to the CleanCut Door.

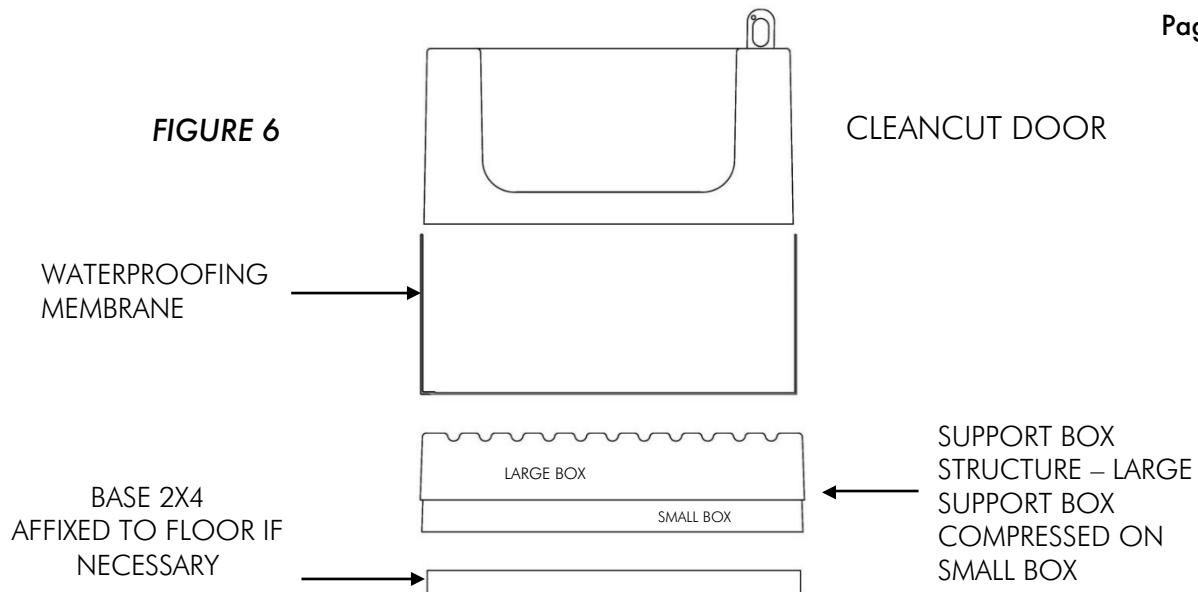

It is important to understand that each tub has variations and modifications may be necessary in the field. For fiberglass and other types of tubs, it may be necessary to adjust the installation of the support boxes based on the framing or support material present on the inside channel of the tub. For example, you may only need to use one of the support box structures based on the height of the bathtub.

1. It may be necessary to adjust the support box structure according to the conditions present during your installation. For example, for wooden sub-floors, begin by screwing or adhering with included adhesive a treated 2x4 directly to the sub-floor to serve as a base for the support structure. For concrete floors, a treated 2x4 is adhered directly to the concrete floor. The 2x4 might need to be cut into several sections if there is a support brace in the cut-out channel.
2. Build the support box structure to appropriate height. If working with a concrete sub-floor, thoroughly inspect and clean the floor in the tub cut-out channel prior to securing the treated 2x4. Remove any materials from the concrete that may cause an uneven surface. Apply adhesive directly to the concrete floor. Insert the 2x4s and thoroughly spread the adhesive on the concrete.
3. Prior to inserting the small support box, it is first necessary to secure a 22 1/2" long 2x4 into the channel of the small support box. Place a bead of adhesive around the inside of the support box and insert the 2x4. Place several screws into the small support box to properly affix the 2x4 into proper position (Figure 7).

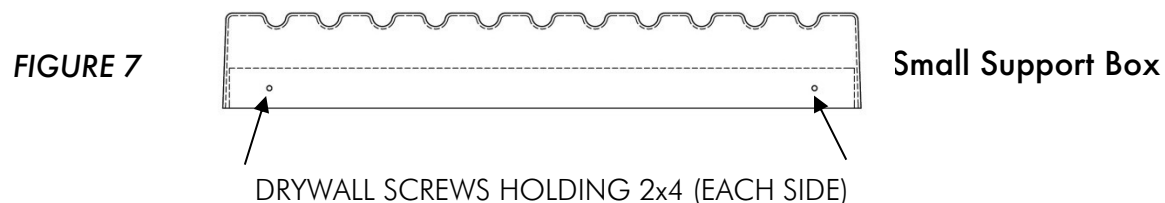

4. Insert the small box in the channel. At this point, do not adhere the small support box to anything. Place the large support box into the channel and over the top of the small box. Place the CleanCut Door into position and compress the CleanCut Door downward to determine the proper height and placement for the support box structure.

5. Once the support of the CleanCut Door has been achieved, remove the Door and mark both the left and right ends of the small box where the large box is compressed while the boxes are in the tub opening channel. Once properly marked, remove both support boxes and label the markings "Left" and "Right" to avoid potential confusion. Uncompress the two support boxes from one another and begin the process to permanently adhere the boxes in proper position.
6. Apply adhesive around the perimeter of the large box. Compress the small and large support box structures back together to the appropriate markings made earlier on the small box. Place the support structure back into the channel and insert the CleanCut Door to verify that proper placement has been achieved. Secure both sides of the support structure by placing 2 screws in each side. Make any final adjustments to the CleanCut Door or the support structure at this time (Figure 8).

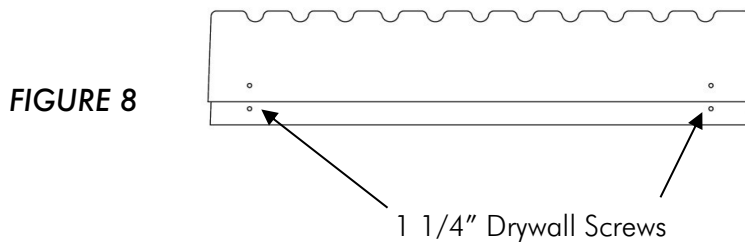

7. Apply adhesive to the tops of the 2x4s that are already in place in the channel if they are needed for height, and insert the support box structure.
8. Place the CleanCut Door into position once more to inspect the fit and position. This is the final opportunity to make any adjustments, if necessary.
9. Once the support structure is properly positioned, you will then apply the waterproof membrane over the entire cut-out portion of the tub. First, unfold the membrane that was included in the installation kit. It will be necessary to cover the entire area of the tub cutout, including the two sidewalls. Remove the paper backing as you go (not all at once) and stretch the membrane material to cover the area over the support boxes and the sidewalls. Adhere approximately 1/4" onto each side of the tub. It will be necessary to trim excess membrane material.
10. Place the CleanCut Door into position once more to inspect the fit and position. Also inspect and make sure that the waterproof wrap is completely covered by the CleanCut Door, and trim off any excess wrap.
11. Apply adhesive to the top of the waterproof membrane. Place a substantial bead of adhesive on the top of the tub where the CleanCut Door will be seated. Adhesive on the top of the tub reinforces the CleanCut Door.
12. Prior to placing the CleanCut Door into the channel, it is necessary to gently pass a low flame several times along the perimeter of the cut-out where the tub is met. This will help promote bonding between the CleanCut Door and the bathtub once adhesive is applied. Use caution when using the torch and do not hold heat on one area of the product as it may discolor or melt.

Place the CleanCut Door into the channel and gently press into place.

Completing the Installation

1. Before finalizing the installation, first make sure the CleanCut Door is in proper position and fully compressed. Press firmly and evenly on the CleanCut Door to ensure proper placement. Do not open the door for the remainder of the installation process.
2. Thoroughly wipe the tub area with isopropyl alcohol where the adhesive will bond and allow enough time to flash off before applying the adhesive. **Do not** apply the isopropyl alcohol directly on the adhesive as it will prevent the adhesive from drying or curing. **Do not** use to clean or smooth your final bead as well.
3. It is necessary to caulk around the entire perimeter of the CleanCut Door. Before beginning to caulk, place the furring/spacing strip that was included with your kit in the channel of the CleanCut Door. Please note that you may need to trim the piece to fit the opening.
4. Begin by using the included adhesive along the sides of the CleanCut Door. Begin on the left side and complete the process, before moving to the right side and bottom. It is recommended that you wear gloves during this step to avoid direct exposure to the adhesive. Run your gloved finger along the beads and wipe the excess on a folded paper towel. Try to smooth the beads one-time only, as the adhesive becomes tacky to the touch quickly.
5. Underneath the bottom edges of the CleanCut Door are a bit more difficult to see and the included angled nozzle should be used for completing this step. Use a small mirror to inspect the bead and to verify that all surfaces have been properly sealed.
6. Spend a few minutes at the end of the job to once again clean up the tub and the bathroom area. Upon completion, place a sign on the CleanCut Door warning not to use the tub for 2 days while the adhesive cures. Once the adhesive has cured, return to remove the spacing device and to inspect your work. Make sure the door opens and latches properly. Please wipe the CleanCut Door and inner seal thoroughly to remove any debris remaining from the installation process. Fill the tub with water and inspect one final time.

IMPORTANT REMINDER – if completing the install on behalf of another, please leave the warranty and care & use information with the end-user at the conclusion of the installation.

The CleanCut Door installation is now complete. Safeway Safety Step, LLC (DBA CleanCut) sincerely thanks you for your interest in the CleanCut Door and looks forward to assisting you in any way possible. Visit our website at www.cleancutbath.com for video installation instructions and answers to frequently asked questions, or call us toll-free at 877-882-7837 with any questions or concerns.